



**Characteristics**



- Energy saving heat pump air curtains: Up to 70% reduction in costs and CO<sub>2</sub> emissions (heating mode).
- Stylish, discreet and contemporary design adaptive to any interior architecture.
- Smooth front panel can be customized with logotypes, lighting, lettering or safety and informative signals, according to the client requirements.
- Self-supporting steel rounded casing with edgeless plastic side covers, finished in structural epoxy-polyester painting white colour RAL9016 as standard. Other colours are available on request.
- Hidden top air entrance, avoiding the inside view of the unit and the inlet grille.
- Anodized aluminium outlet vanes, airfoil shaped, adjustable from 0 to 15° each side.
- EC Double-inlet centrifugal fans driven by an external rotor motor and low noise level, with very low consumption efficient fans.
- Includes direct expansion coil with sensors. Optional condensate water pump.
- CS-5DX-NE Plug&Play control with 5 speeds and telephone cable 7m included.
- Requires MITSUBISHI ELECTRIC DX Interface KIT adapted for air curtain and programmable control, please consult.
- Ready to connect to MITSUBISHI ELECTRIC Standard and Power Inverter outdoor heat pump unit (R410A) with expansion valve, not included, the customer should purchase it.

**Specifications**

Model	Airflow m <sup>3</sup> /h	Outdoor Unit (*) 230Vx1	Outdoor Unit (*) 400Vx3	Power Fans 230V-50Hz kW	Current Fans 230V-50Hz A	Noise Level (5 m) dB(A)	Weight kg
SMART ECM 1000 DX8-ME	1640	PUHZ-ZRP71VHA	-	0,132	1,14	54	39
SMART ECM 1500 DX11-ME	2460	PUHZ-ZRP100VKA	PUHZ-ZRP100YKA	0,198	1,71	55	58
SMART ECM 1500 DX13-ME	2460	PUHZ-ZRP125VKA	PUHZ-ZRP125YKA	0,198	1,71	55	58
SMART ECM 2000 DX16-ME	3280	PUHZ-ZRP140VKA	PUHZ-ZRP140YKA	0,264	2,28	56	73
SMART ECM 2500 DX22-ME	4100	-	PUHZ-ZRP200YKA	0,330	2,85	57	79
SMART ECM 2500 DX24-ME	4100	-	PUHZ-ZRP250YKA	0,330	2,85	57	79
SMART ECM 3000 DX26-ME	4920	-	PUHZ-ZRP250YKA	0,396	3,42	58	91
SMART ECG 1000 DX10-ME	2190	PUHZ-ZRP100VKA	PUHZ-ZRP100YKA	0,225	1,95	59	44
SMART ECG 1500 DX14-ME	2920	PUHZ-ZRP125VKA	PUHZ-ZRP125YKA	0,300	2,60	60	64
SMART ECG 2000 DX22-ME	4380	-	PUHZ-ZRP200YKA	0,450	3,90	61	83
SMART ECG 2000 DX24-ME	4380	-	PUHZ-ZRP250YKA	0,450	3,90	61	83
SMART ECG 2500 DX27-ME	5110	-	PUHZ-ZRP250YKA	0,525	4,55	62	87
SMART ECG 3000 DX27-ME	5840	-	PUHZ-ZRP250YKA	0,600	5,20	63	99

(\*) Includes direct expansion valve.

MITSUBISHI Power Inverter (*) Outdoor Units	Heating Capacity kW	Heating Power kW	SCOP or COP	Cooling Capacity kW	Cooling Power kW	SEER or EER	Power Supply	Pipes Gas Liquid inch	Pipes Minimum Length m	Pipes Maximum Length m	Pipes Maximum Height m
PUHZ-ZRP71VHA	8,0	2,03	3,90	7,1	2,01	5,60	230Vx1	5/8 3/8	-	50	30
PUHZ-ZRP100VKA	11,2	2,06	4,20	10,0	2,63	5,60	230Vx1	5/8 3/8	-	75	30
PUHZ-ZRP100YKA	11,2	2,06	4,20	10,0	2,63	5,50	400Vx3	5/8 3/8	-	75	30
PUHZ-ZRP125VKA	14,0	3,63	3,86	12,5	4,05	3,09	230Vx1	5/8 3/8	-	75	30
PUHZ-ZRP125YKA	14,0	3,63	3,86	12,5	4,05	3,09	400Vx3	5/8 3/8	-	75	30
PUHZ-ZRP140VKA	16,0	4,20	3,81	13,4	4,36	3,07	230Vx1	5/8 3/8	-	75	30
PUHZ-ZRP140YKA	16,0	4,20	3,81	13,4	4,36	3,07	400Vx3	5/8 3/8	-	75	30
PUHZ-ZRP200YKA	22,4	6,94	3,23	19,0	6,46	2,94	400Vx3	1 3/8	-	100	30
PUHZ-ZRP250YKA	27,0	8,94	3,75	22,0	8,31	2,65	400Vx3	1 1/2	-	100	30

(\*) Also compatible with Standard Inverter outdoor units.

Energy efficiency: SCOP/SEER seasonal ≤12kW, COP/EER >12kW.

Outdoor unit capacities depending on standard conditions: heating 20°CDB indoor / 7°CDB and 6°CWB outdoor, cooling 27°CDB and 19°CWB indoor / 35°CDB outdoor.

When adverse weather conditions, the outdoor unit capacity can decrease. It is recommendable to oversize the units.



## Characteristics



- Energy saving heat pump air curtains: Up to 70% reduction in costs and CO<sub>2</sub> emissions (heating mode).
- Stylish, discreet and contemporary design adaptive to any interior architecture.
- Smooth front panel can be customized with logotypes, lighting, lettering or safety and informative signals, according to the client requirements.
- Self-supporting steel rounded casing with edgeless plastic side covers, finished in structural epoxy-polyester painting white colour RAL9016 as standard. Other colours are available on request.
- Hidden top air entrance, avoiding the inside view of the unit and the inlet grille.
- Anodized aluminium outlet vanes, airfoil shaped, adjustable from 0 to 15° each side.
- EC Double-inlet centrifugal fans driven by an external rotor motor and low noise level, with very low consumption efficient fans.
- Includes direct expansion coil with sensors. Optional condensate water pump.
- CS-5DX-NE Plug&Play control with 5 speeds and telephone cable 7m included.
- Requires MITSUBISHI ELECTRIC VRF Interface KIT adapted for air curtain with expansion valve and programmable control, please consult.
- Ready to connect to MITSUBISHI ELECTRIC VRF outdoor heat pump unit (R410A), not included, the customer should purchase it.

## Specifications

Model	Airflow m <sup>3</sup> /h	Power Fans 230V-50Hz kW	Current Fans 230V-50Hz A	Noise Level (5 m) dB(A)	Weight kg	Mitsubishi Electric Kit Interface VRF (*)
SMART ECM 1500 VRF12-ME	2460	0,198	1,71	55	58	PAC-AH125M-J
SMART ECM 2000 VRF16-ME	3280	0,264	2,28	56	73	PAC-AH125M-J
SMART ECM 2000 VRF19-ME	3280	0,264	2,28	56	73	PAC-AH250M-J
SMART ECM 2500 VRF21-ME	4100	0,330	2,85	57	79	PAC-AH250M-J
SMART ECM 2500 VRF24-ME	4100	0,330	2,85	57	79	PAC-AH250M-J
SMART ECM 3000 VRF26-ME	4920	0,396	3,42	58	91	PAC-AH250M-J
SMART ECM 3000 VRF30-ME	4920	0,396	3,42	58	91	PAC-AH250M-J
SMART ECG 1000 VRF10-ME	2190	0,225	1,95	59	44	PAC-AH125M-J
SMART ECG 1500 VRF13-ME	2920	0,300	2,60	60	64	PAC-AH125M-J
SMART ECG 1500 VRF15-ME	2920	0,300	2,60	60	64	PAC-AH125M-J
SMART ECG 2000 VRF20-ME	4380	0,450	3,90	61	83	PAC-AH250M-J
SMART ECG 2000 VRF24-ME	4380	0,450	3,90	61	83	PAC-AH250M-J
SMART ECG 2500 VRF25-ME	5110	0,525	4,55	62	87	PAC-AH250M-J
SMART ECG 2500 VRF29-ME	5110	0,525	4,55	62	87	PAC-AH250M-J
SMART ECG 3000 VRF29-ME	5840	0,600	5,20	63	99	PAC-AH250M-J

(\*) Includes direct expansion valve.

MITSUBISHI ELECTRIC VRF compatible Outdoor Units	
Range	Series
City Multi	SY (Heat Pump)
City Multi	R2 (Heat Recovery)
Mr. Slim	Standard Inverter
Mr. Slim	Power Inverter
Mr. Slim	Zubadan
Industrial	Standard Inverter
Industrial	Power Inverter

When adverse weather conditions, the outdoor unit capacity can decrease. It is recommendable to oversize the units.



**Dimensions**

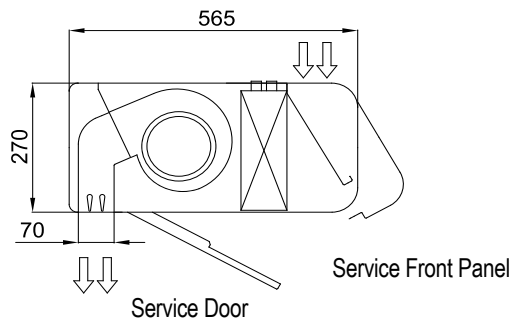
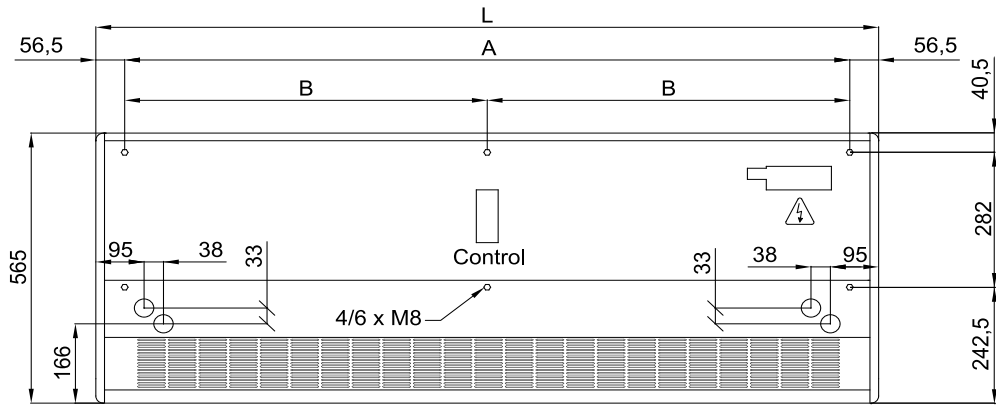

	L	A	B
SMART 1000	1034	920	-
SMART 1500	1534	1420	710
SMART 2000	2034	1920	960
SMART 2500	2534	2420	1210
SMART 3000	3034	2920	1460

**Finishes and Details**

